



Hand held Mixers Motor Unit for Bermixer PRO 350 W

ITEM # _____

MODEL # _____

NAME # _____

SIS # _____

AIA # _____



600309 (DBPU350)

Motor unit, variable speed up to 9000 rpm - 350 W

Short Form Specification

Item No. _____

350W flat base motor unit for handheld mixer. Stainless steel tubes (various lengths) and whisk available upon request, to mix, liquidize, whip or emulsify. IP55 water protected control panel.

Main Features

- Flat base motor unit.
- Delivered with space saving storing wall support.
- Light weight, ergonomic grip and adjustable speeds make preparation tasks fast and easy.
- Overheating warning red indicator.
- Safety feature requires both hands to start the mixer (no volt release system).
- Designed to be used directly in stew pots up to 30 - 50 lt, depending on the tube size.
- Bayonet system makes fast and simple to exchange tools.
- Productivity suitable for 50 to 300 meals per service.

Construction

- Power: 350 watts.
- Maximum speed 9000 rpm.
- Motor has an air cooling system and is protected against overheating (in case of long intensive work).
- Smart speed control to ensure the right power according to the work load.
- Water protected motor unit (controls are IP55, IP34 throughout machine).

Optional Accessories

- Reinforced whisk for portable Bermixer PNC 650108
- 353 mm stainless steel tube for portable mixer bermixer PNC 650132
- 453 mm stainless steel tube for portable mixer bermixer PNC 650133
- Adjustable rail for containers diam. 375 mm to 650 mm (to be used with 653294) PNC 653292
- Holder to support portable mixer in containers (can be used only with tube attachment) PNC 653294

APPROVAL: _____

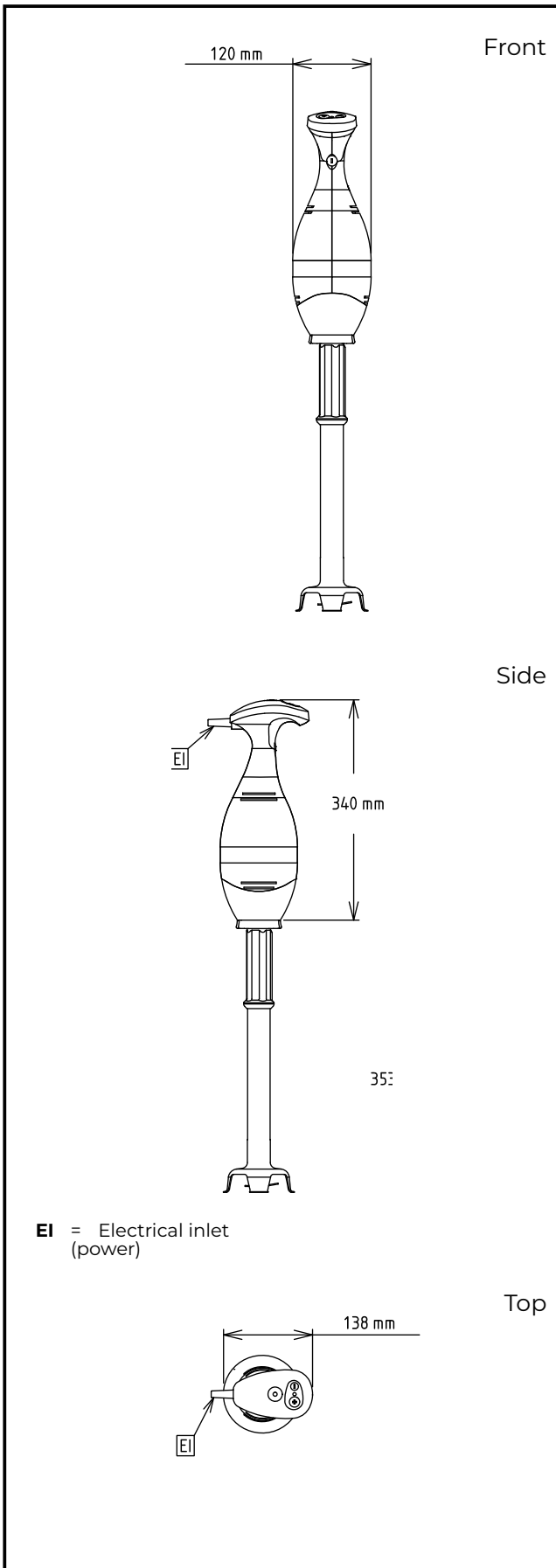

Electric

Supply voltage:

600309 (DBPU350)

220-240 V/1 ph/50/60 Hz

Electrical power max.:

0.35 kW

Total Watts:

0.35 kW

Key Information:

External dimensions,

Width:

138 mm

External dimensions,

Depth:

120 mm

External dimensions,

Height:

340 mm

Shipping weight:

3 kg